

3D Take-away creation

Project Make

Due: 4th period: Tuesday 3/15

5th period: Wednesday 3/16

Your task:

Create something in Tinkercad by starting with a large block, and then **ONLY** taking away from that block by grouping "hole" objects with the block until your creation shows through. Imagine that you are a stone carver, starting with a block of stone, chipping away pieces to reveal your creation. Your creation should be something obvious, real, imagined, or just super cool.

Please start with a rectangular block that is 100 by 50 by 50:

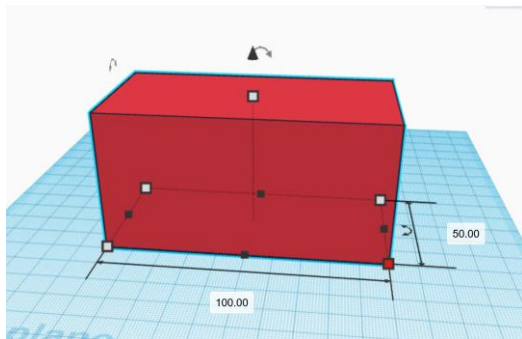

Then, using only hole objects (any type of hole objects are fine) remove parts of the big block to reveal something that you want to create as what is left over.

For example, I created the following:

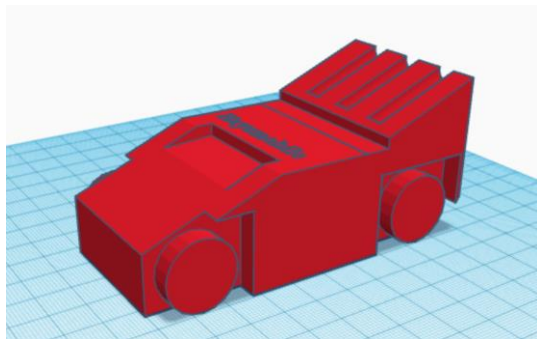

You can use as many different types of hole pieces as you want and you can group them along the way, or all at once, or in any combinations. The final result, though, needs to be **ONLY WHAT IS LEFT AFTER YOU HAVE TAKEN AWAY A BUNCH OF THINGS FROM THE ORIGINAL LARGE BLOCK**. Imagine that you are a stone carver chopping pieces off a big block, revealing an incredible masterpiece underneath.

See my creation if I ungroup everything on the next page:

